

Smithsonian

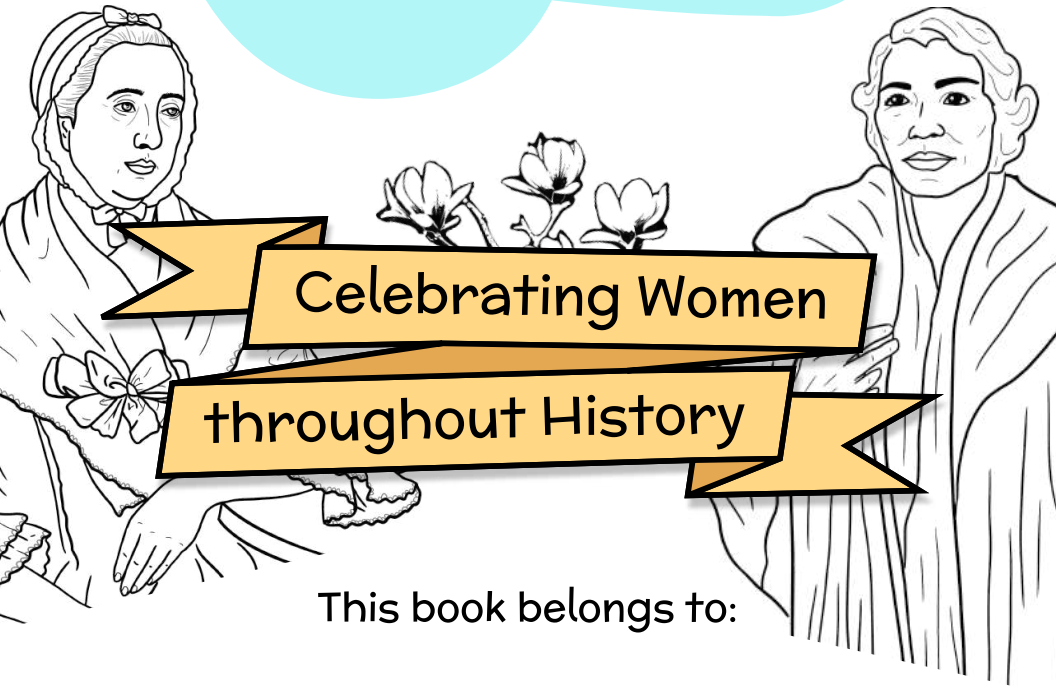

Coloring our World



Celebrating Women

throughout History

This book belongs to:

Women make history in different ways. Lighting the way for others to follow is one way to make and shape history and communities. Can you imagine being the first woman to work in a job or profession that had always been for a man? Think of the challenges! All the extraordinary women in this coloring book made history by being courageous and creating solutions to problems big and small. Enjoy these stories, and do not forget to dream and think to yourself, **“How can I make history?”**

Use the tag **#BecauseOfHerStory**
to share your artwork with us!



From the Smithsonian: American Women's History Initiative, Office of Advancement, Office of Communications and External Affairs, Office of the Under Secretary for Education and the Smithsonian education community. Creative services and design by Smithsonian Digital Studios.

This project received support from the Smithsonian American Women's History Initiative.

womenshistory.si.edu/donors

Credits

Smithsonian Gardens
Wikimedia Commons

Anne Catharine Hoof Green
by Charles Willson Peale
1769, Oil on canvas
National Portrait Gallery, Smithsonian Institution; partial gift with funding from the Smithsonian Collections Acquisitions Program and the Governor's Mansion Foundation of Maryland

KeramicstudioV_0300.tif.
Illustration by Mrs. Dante C. Babbitt.
Ceramic Studio, Volume 5 (1904), P. 252.
Smithsonian Libraries and Archives

bulletinunitdst821915unit_0144.jp2:
Illustration by Serena Katherine "Violet" Dandridge.
Bulletin of the United States National Museum, no. 82 (1915). Fig 77, page 130.
Smithsonian Libraries and Archives

Olivetti Studio 46 Typewriter Used by Octavia Butler
Anacostia Community Museum

Lockheed Vega 5B, Amelia Earhart
National Air and Space Museum
Gift of the Franklin Institute

Amelia Earhart
National Portrait Gallery, Smithsonian Institution;
by Underwood & Underwood
1937, Gelatin silver print
gift of George R. Rinhart,
in memory of Joan Rinhart

Marian Anderson
by Betsy Graves Reyneau
1955, Oil on canvas
National Portrait Gallery, Smithsonian Institution; gift of the Harmon Foundation
©Peter Edward Fayard

Mary McLeod Bethune
by Betsy Graves Reyneau
1943, Oil on canvas
National Portrait Gallery, Smithsonian Institution; gift of the Harmon Foundation
©Peter Edward Fayard

Lisa Stevens
October 11, 2006,
by Meghan Murphy.
National Zoological Park,
Image no. 20061011-1149MM.

Esperanza Spalding
By Sandrine Lee
2010 (printed 2012), Digitally exposed chromogenic print
National Portrait Gallery, Smithsonian Institution; gift of Sandrine Lee

Textiles of the Philippines
by PJ Gubatina Pollicarpio and Ida Noelle Calumpang
Smithsonian Asian Pacific American Center's Culture Lab pop-up museum, 'Crosslines: A Culture Lab on Intersectionality,' in 2016."

Headshot of Ida Noelle Calumpang
by Les Talusan

Hummingbird Image
Smithsonian's National Zoo

Ruby Throated Hummingbird
Illustration by Anne Balogh
Migratory Bird Center, Smithsonian's National Zoo and Conservation Biology Institute,
©2009

Mary Fields
Wikimedia Commons

Unidentified Woman
National Portrait Gallery, Smithsonian Institution;
Partial gift of Sarah Bache

Plastic brush with box from Mae's Millinery Shop
Collection of the Smithsonian National Museum of African American History and Culture,
Gift of Donna Limerick

The Sweet Bay Magnolia is a symbol for perseverance. The Sunflower is a symbol of pride. The Hibiscus is a symbol for delicate beauty.

Think about what types of flowers are in your neighborhood. At your school?

What special meaning could they have?

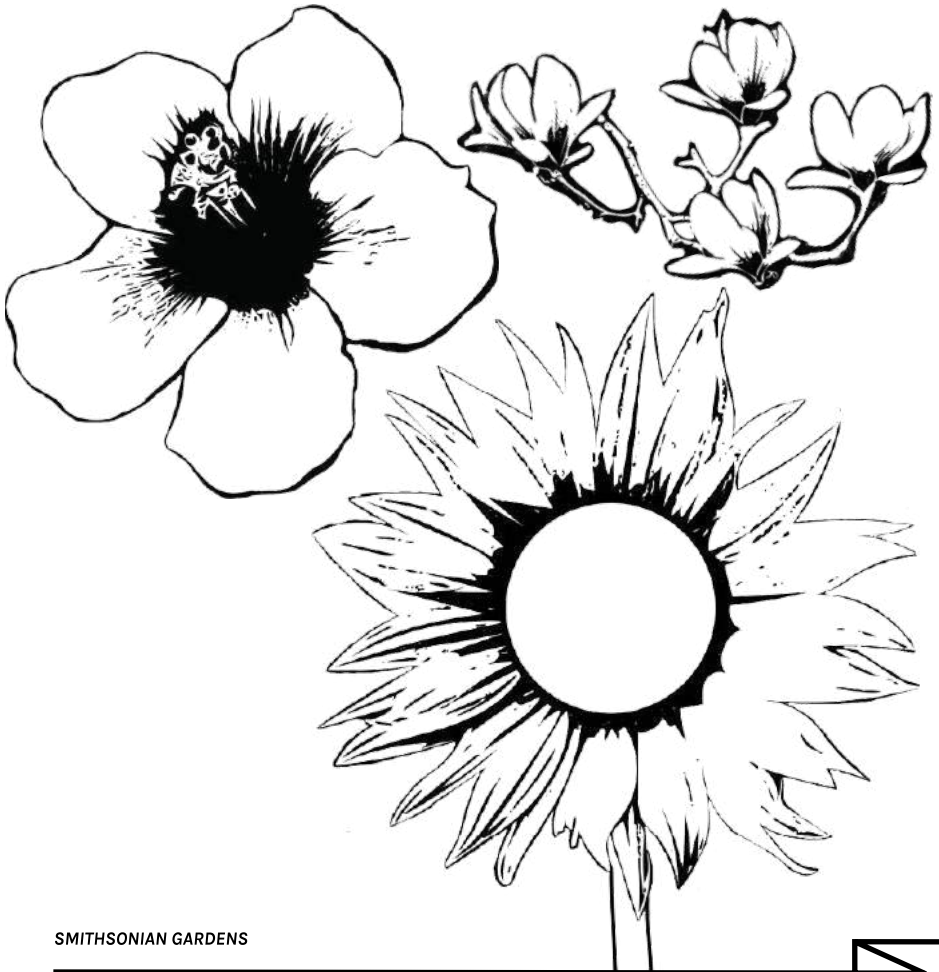

SMITHSONIAN GARDENS

Anne Spencer was the first African American woman to be published in the Norton Anthology of Poetry. Many of her poems explore the symbolic power of flowers and nature, as well as the joy she had for gardening. Her home garden in Virginia served as a space for many African American thinkers, including poet Langston Hughes, writer James Weldon Johnson, and civil rights leader Dr. Martin Luther King, Jr.

Anne Catharine Hoof Green was one of a small number of women printers during the colonial period. She led the Maryland Gazette newspaper for eight years.

NATIONAL PORTRAIT GALLERY



Describe Green's clothing

What is Green holding in her hand?

What three colors is Green wearing?

What do those three colors symbolize?

The original book page includes instructions for exactly what colors to use for her design of this plate. If you don't want to include apple green and deep blue, feel free to choose your own shades.

You could use primary colors, like red, yellow, and blue;
or consider mixing colors to create new shades.
Red and yellow make orange, yellow and blue make green,
red and blue make purple!



SMITHSONIAN LIBRARIES AND ARCHIVES

Mrs. Dante C. Babbitt was one of many talented female illustrators whose work was highlighted in *Keramic Studio*, a ceramics design journal started by Adelaide Alsop-Robineau in 1899.

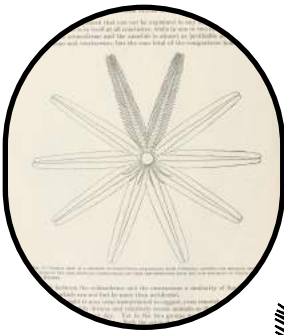

Can you finish Violet Dandridge's scientific drawing of a *Comatulella brachiolata*, a marine animal found in Australia? Notice how both sides are symmetrical, meaning if you drew a line down the middle of the picture, it would be the same on both sides. Try and sketch your side to complete the drawing.

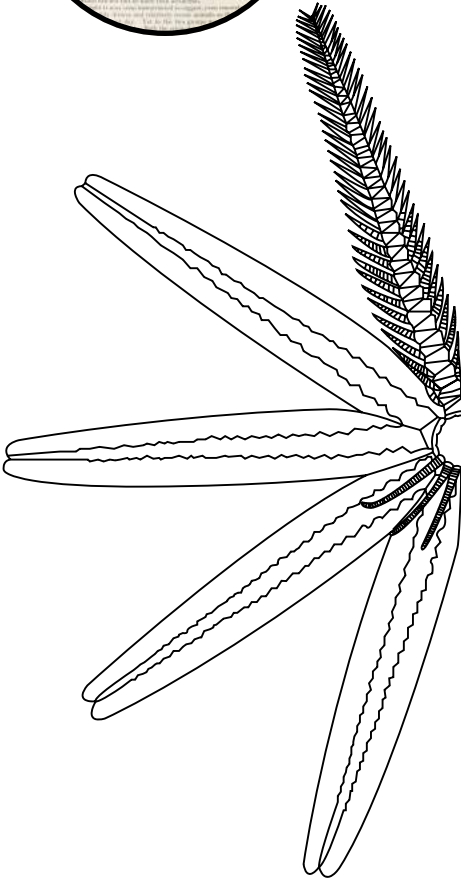

SMITHSONIAN LIBRARIES AND ARCHIVES

Mrs. Serena Katherine “Violet” Dandridge moved to Washington, D.C. in 1896 to study art. In the early 1900s, she partnered with zoologists as a scientific illustrator and painter for exhibitions at the Smithsonian. After returning home to West Virginia, Dandridge joined the suffrage movement and fought for a woman's right to vote.

In 1932, **Amelia Earhart** became the first female pilot to fly solo and nonstop across the Atlantic Ocean. Later that year, she set a distance record flying from Los Angeles, CA to Newark, NJ in 19 hours and 5 minutes! Earhart became one of America's most famous pilots breaking records in this bright red Lockheed Vega 5B.

NATIONAL AIR AND SPACE MUSEUM

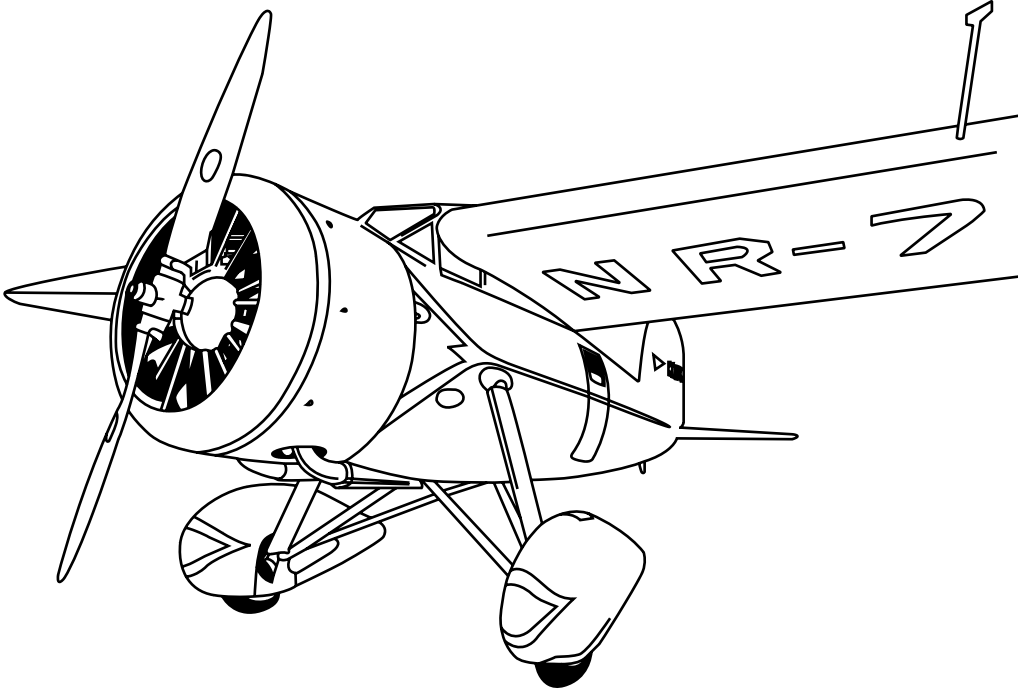

Look at a map of the United States to see just how far she flew! First, find Los Angeles, CA. Next, find Newark, NJ. Move your finger across the map to follow her flight.



Internationally acclaimed contralto singer **Marian Anderson** became a powerful symbol in the American struggle for racial equality in the spring of 1939, when she performed at the Lincoln Memorial before a crowd of 75,000.

NATIONAL PORTRAIT GALLERY

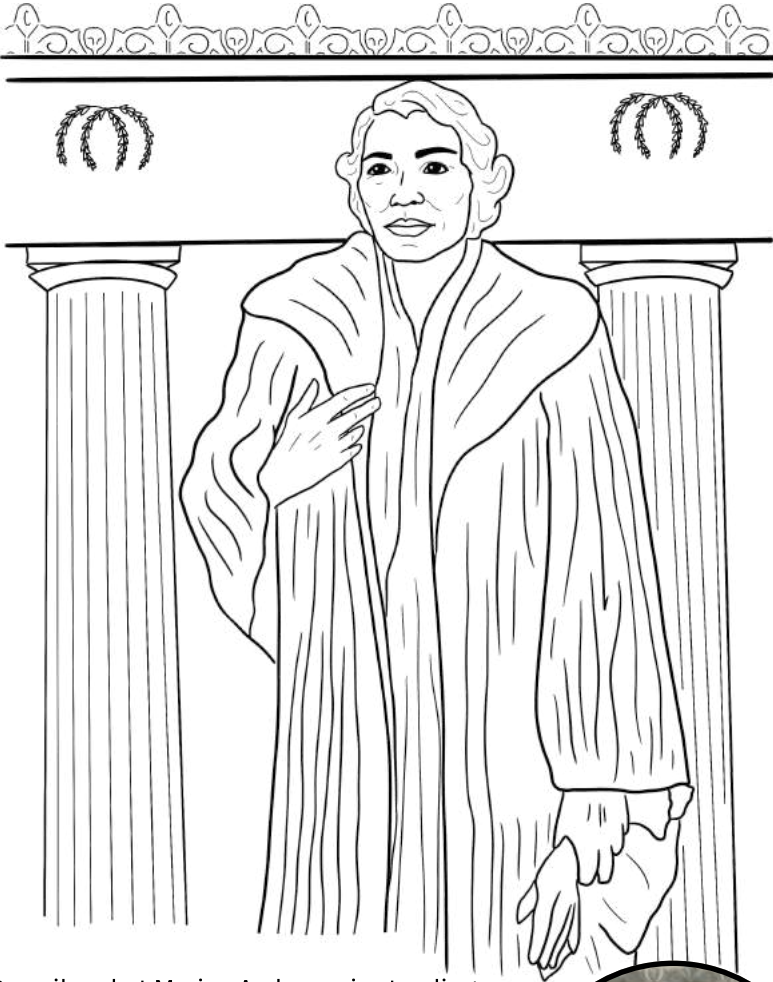

Describe what Marian Anderson is standing in front of. What can the setting tell us about her?

Based on the expression on her face, what emotion do you think she is feeling?

What can her clothing and hairstyle tell you about her profession and place in history?



Strike the same pose as Mary McLeod Bethune.

What is she doing? How would you describe her personality based on her pose?

What objects are in the portrait? What might they be telling us about Mary McLeod Bethune's story?



NATIONAL PORTRAIT GALLERY

Civil Rights activist and educator **Mary McLeod Bethune** was born in Mayesville, SC. She spent most of her life pursuing education and social justice for African Americans.

What do you think the future might be like?
10 years from now? 100 years from now?

Tell a friend a story sharing what
you predict!

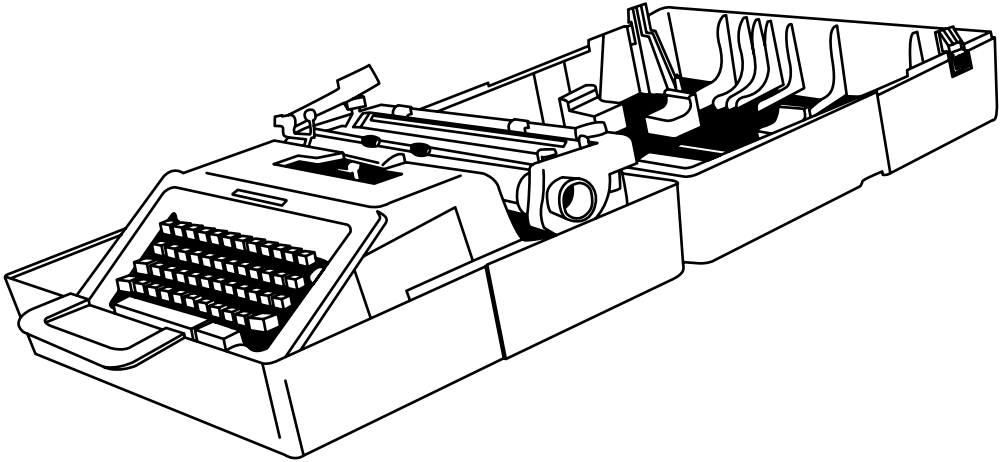

ANACOSTIA COMMUNITY MUSEUM

African American author **Octavia E. Butler** had a passion for writing stories since she was 10 years old. In the 1970s, a manual typewriter, like this one, was used to type on paper without electricity. Butler used this typewriter to create futuristic novels that inspired readers of African descent to imagine themselves as scientists, adventurers, and heroes.

Lisa Stevens was a curator of mammals at the National Zoo for thirty years. In 2005, she oversaw the birth of Tai Shan, the Zoo's first surviving panda cub, earning her the nickname "Panda Lady." In 2013, Bao Bao, Tai Shan's little sister, was born.

SMITHSONIAN'S NATIONAL ZOO AND CONSERVATION BIOLOGY INSTITUTE

宝 宝
BaoBaoPanda
Smithsonian's National Zoo™



Look closely at the coloring section of this page.
What plant do you think it is that surrounds
the giant panda?

Did you know giant pandas eat 20 to 40 pounds
of food a day? They spend most of their day
looking for food and eating bamboo to get all
the nutrients they need!

Jazz bassist and singer **Esperanza Spalding** electrified the Grammy Awards in 2011 when she won honors as Best New Artist. In interviews, Spalding has emphasized that music does not only happen in recording studios and concert halls, but also in more intimate, everyday spaces.

NATIONAL PORTRAIT GALLERY



What objects are in the portrait? What story do they tell about Esperanza Spalding?

How is she posed? How would you describe her personality?

What shapes do you see? What patterns of repeating shapes do you notice?

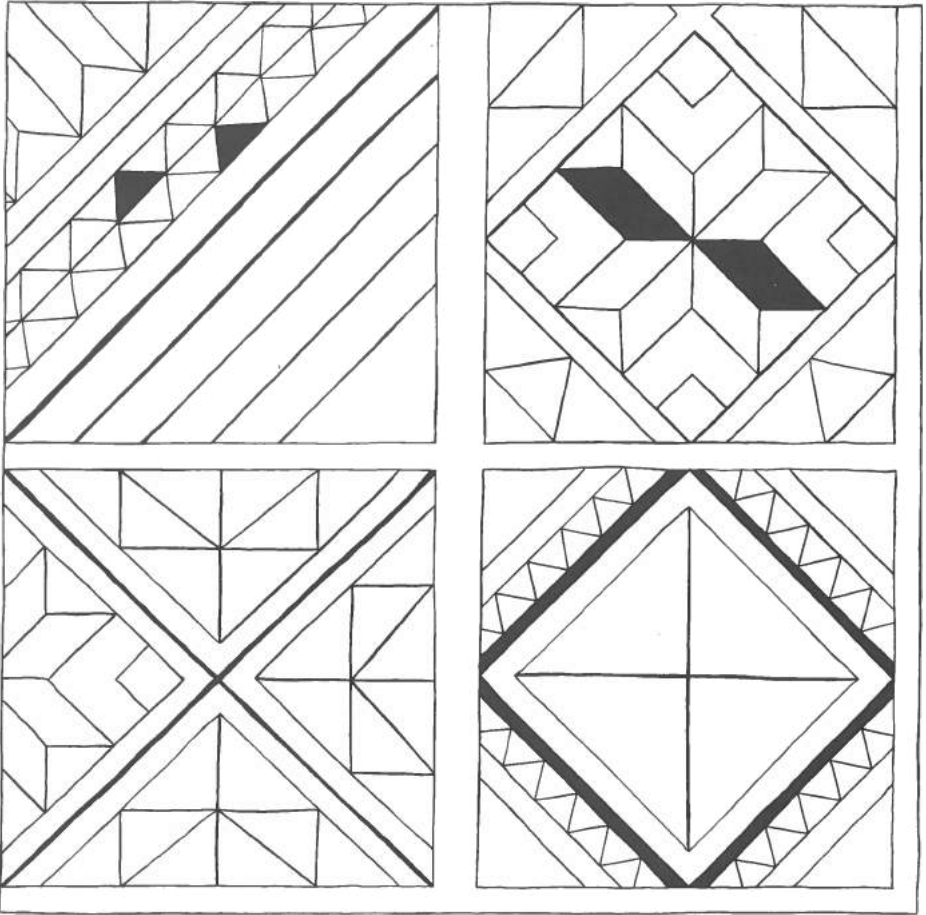

SMITHSONIAN ASIAN PACIFIC AMERICAN CENTER

Illustrator **Ida Noelle Calumpang** created representations of original tribal textile designs from the Philippines to honor the detailed handmade tradition of Filipino textile making.



Did you know that hummingbirds hatch from eggs the size of a small pea? In 2016, Spot, a ruby-throated hummingbird from nearby Virginia, was brought to the Smithsonian's National Zoo in Washington, D.C. for care. Spot was just a young chick and he had fallen into a swimming pool and almost drowned. The injuries from Spot's fall made releasing him back into the wild not a good option, so he now lives at the Zoo.

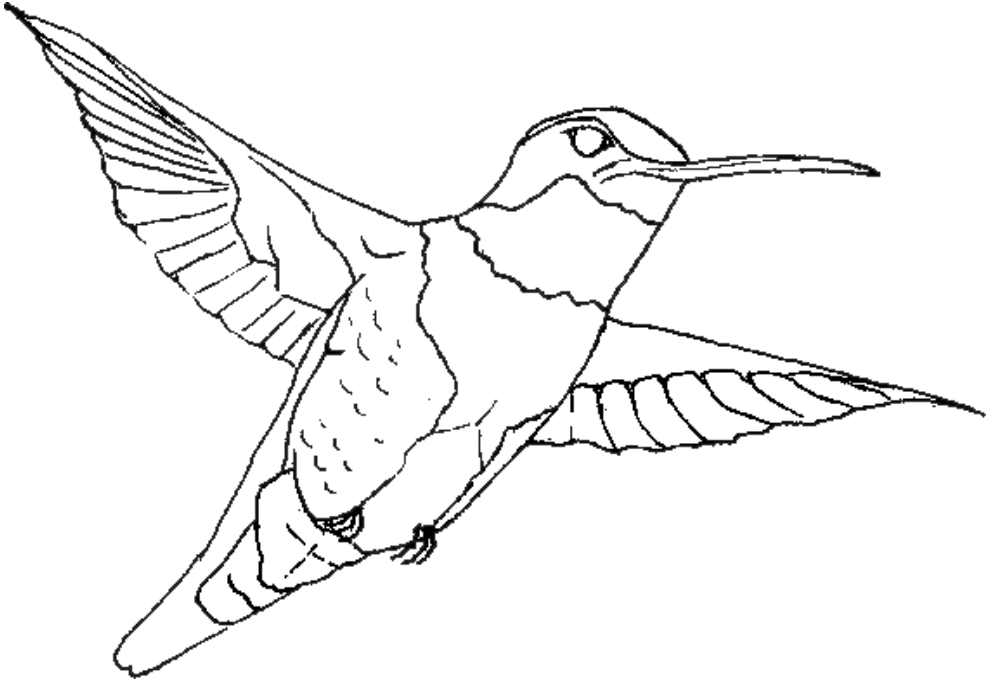

SMITHSONIAN MIGRATORY BIRD CENTER

Bird House keeper **Lori Smith** and curator **Sara Hallager** say that Spot has a lot of personality for being such a small bird. At the Zoo, Spot's diet consists of a sweet nectar designed specifically for hummingbirds. At his last weigh-in, Spot tipped the scales at 3.6 grams—that's 1.4 grams less than a nickel!

In 1895, **“Stagecoach Mary Fields”** was the first African American woman, and only the second woman, to work in the United States Postal Service. She was hired as a mail carrier because she was the fastest to hitch a team of six horses. She got the nickname “Stagecoach” because she never missed a day of work, even showing up during heavy snow by wearing snowshoes and carrying mail packs on her back.

1. Use this space to write a postcard to a friend!
2. Don't forget to add a postage stamp in the top right corner.
3. Then, color the opposite side too.



NATIONAL POSTAL MUSEUM

A large rectangular frame containing a horizontal line near the top, three vertical lines below it, and a box in the bottom right corner with the text "Place Stamp Here" written vertically.

BECAUSE OF
HER
STORY

